



スピーカシステム
Speaker System

Model No.

TPS-049

26 June 2003

■位相反転型

■Bass Reflex Type

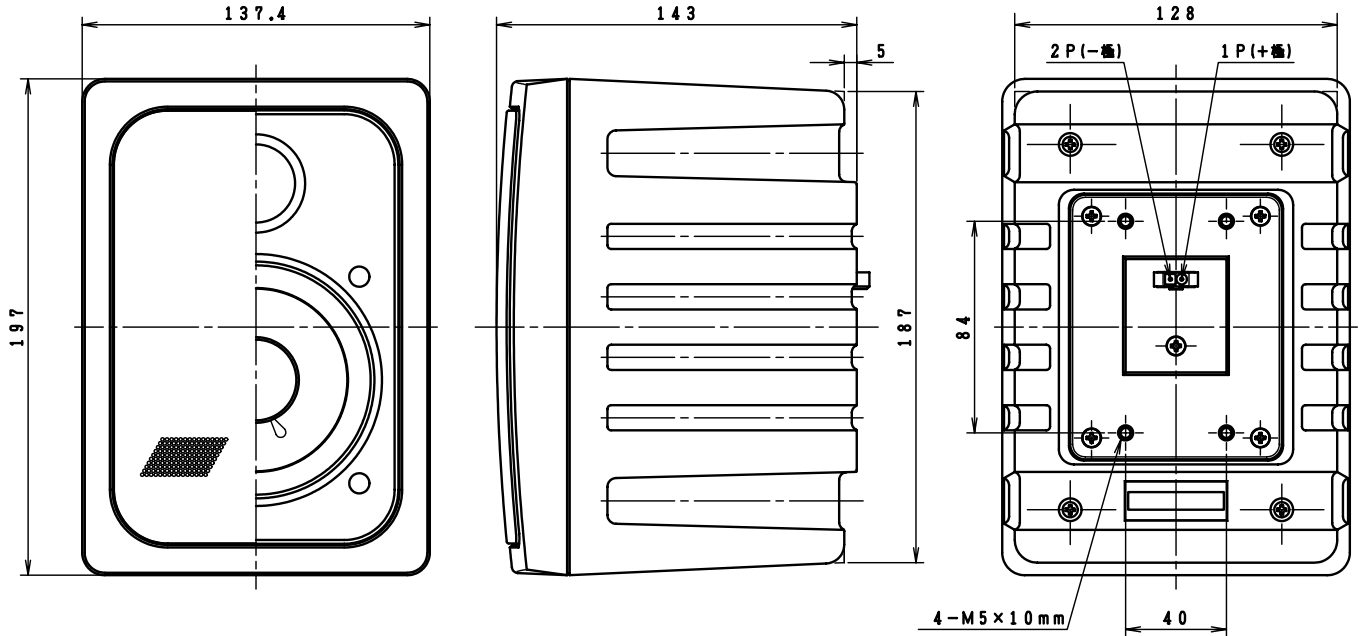

■Specifications■

Speaker Components	-----	10 cm Full Range Type
Nominal Impedance	-----	8 Ω
Nominal Power	-----	30W
Maximum Power	-----	90W
Resonance Frequency	-----	F1=50 / F2=150 Hz
Effective Frequency Range	-----	100~20,000 Hz
Sound Pressure Level	-----	85 dB W/m
Net Weight	-----	1,310 g (46.2 oz.)

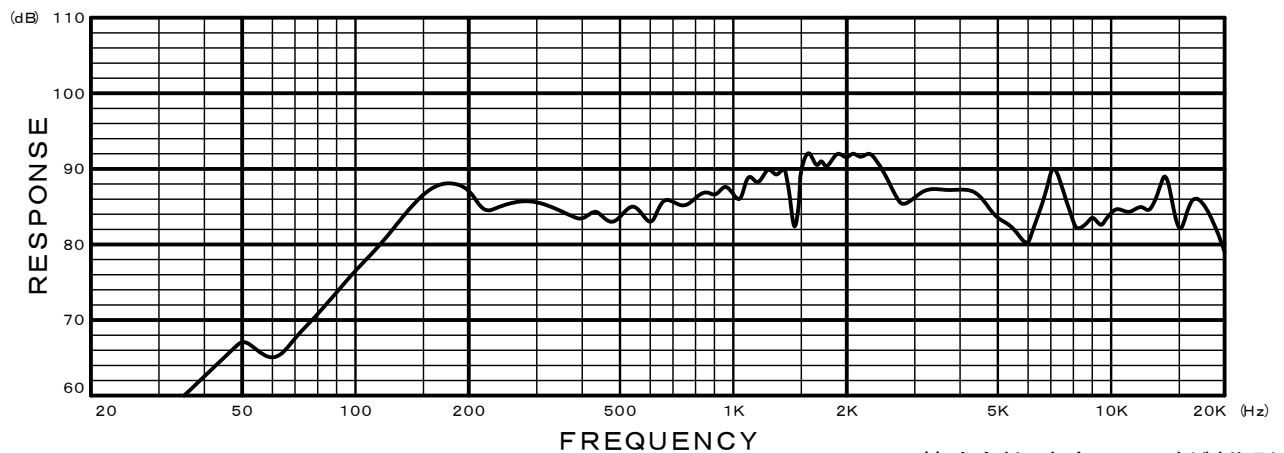

株式会社 東京コーン紙製作所
TOKYO CONE PAPER MFG.CO.,LTD.